



**Kennedy**

INTEGRATED HYGIENE SOLUTIONS

Kennedy Hygiene Products Limited  
Brookside, Uckfield,  
East Sussex, TN22 1YA  
United Kingdom  
Telephone: +44 (0)1825 768141  
Fax: +44 (0)1825 768143  
email: sales@kennedy-hygiene.com  
Website: www.kennedy-hygiene.com

## **PRODUCT SPECIFICATION SHEET**

### **TEKNA ELLIPSE MECHANICAL RETRACTABLE CABINET**

**KHP Part No: CAB TEK ELP**

#### **DESCRIPTION**

- Fully retractable standard width cotton towel cabinet
- Designed to be used with 40m long standard width towels, up to maximum width of 270mm
- Replaceable front insert
- Clean towel stored above used towel in transparent ABS bin for total separation
- Stop mechanism to control towel consumption
- Mechanism can be easily removed without tools
- Self supporting cover with snap shut action
- Transparent side windows for easy towel level indication
- Left/right hand lock. Lock uses key common with other products in the range.

#### **DIMENSIONS**

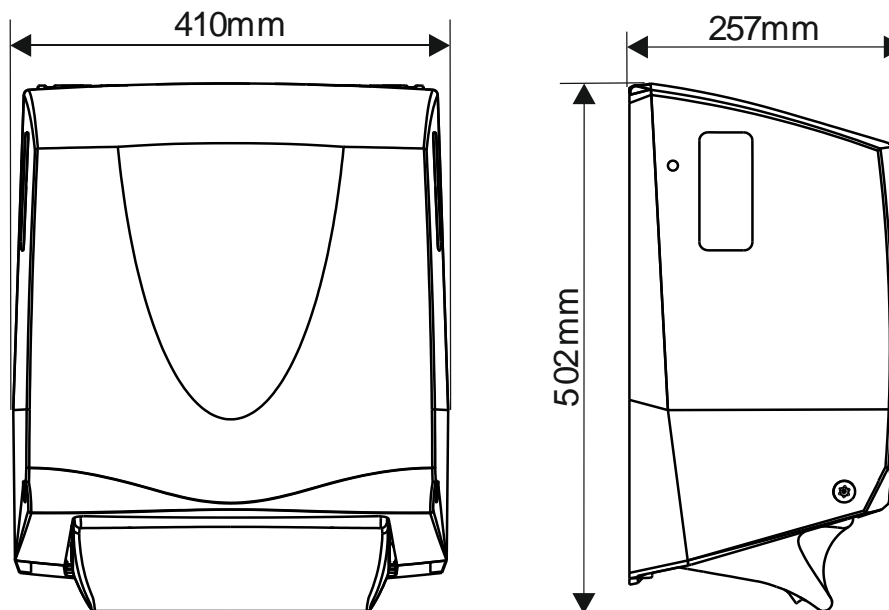

#### **MATERIALS**

Constructed from ABS, other engineering thermoplastics and metal fabrication where necessary for strength and reliability.

Cabinet can be recycled or disposed of in accordance with local regulations.

#### **PACKING**

A single cabinet is packed into a double wall box with key and instruction sheet.

Box dimensions: 50cm x 43cm x 26cm

Individual weight: 8.4 kg