

Tekna Ellipse

Mechanical retractable cotton roll towel (CRT) cabinet



Range

Hand drying

Product Code

CABTEK ELP

Tekna Ellipse is the most advanced cotton towel hand drying solution. It provides unrivalled hygiene, service and environmental benefits while delivering a 'comfort like home' hand drying experience for the end user.

Tekna Ellipse features automatic retraction of each used towel portion and of the towel end; and delivers 200 portions of clean towel from a standard 40 m towel.

This cabinet helps protect the environment as it combines eco-friendly engineering with the cotton towel - a natural biodegradable consumable.

Finishes available

- Arctic White
- Designer Grey
- Chrome

Customised insert designs available

- White
- Turquoise
- Red
- Beige
- Metal
- Carbon
- Wood
- Water drops

¹ Customised inserts are available with the Arctic white finish. Designer grey, chrome and satin finishes come with a black insert.

Benefits

Reliability and durability

- Unique, modern and compact design
- Automatic retraction of clean towel portion for each user
- Clean towel isolated from and positioned above used towel

Reliability & durability

- 40 years' experience in cabinet engineering

- Proven ultra-robust mechanism
- Lockable cabinet to prevent unauthorised access

Ease of service

- Instant towel check through transparent reservoir
- Lock located at both sides to maximise fitting options
- Seamless loading for guaranteed easy servicing

Environmentally friendly

- Mechanical operation – no external power source required
- Cotton towels are one and a half times less harmful to the environment than paper equivalents *
- 100% recyclable components



INTEGRATED HYGIENE SOLUTIONS

* Source ETSA lifecycle analysis study 2007

Technical Specifications

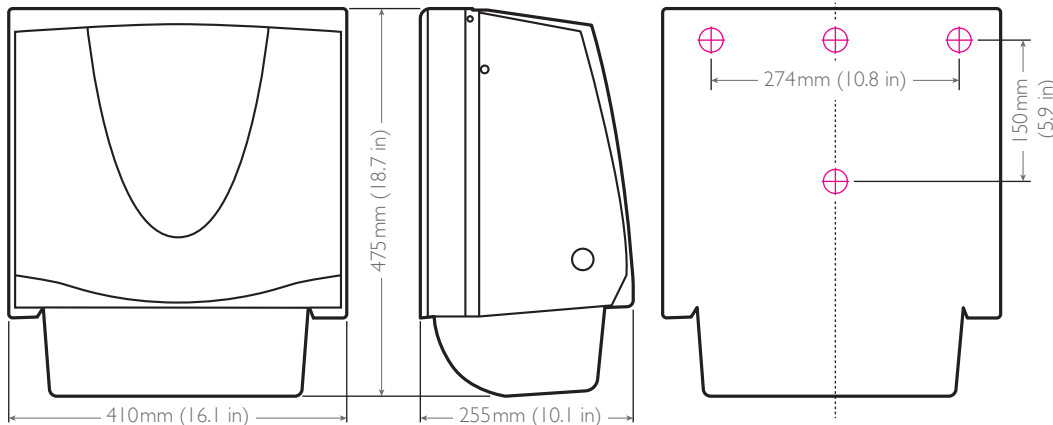

HEIGHT

475mm (18.7 in)

WIDTH

410mm (16.1 in)

DEPTH

255mm (10.1 in)

⊕ FIXING POINTS

Ø : 6mm (0.2 in)

Consumables

40m standard cotton roll towel provides 200 towel portions.

Towel usage/service frequency:

- Medium to high traffic:
 - 4-5 users per cabinet 3 times per day = towel change every 2 weeks
 - 8-10 users per cabinet = weekly towel change

Materials

Constructed from ABS, other engineering thermoplastics and metal fabrication where necessary for strength and reliability. Cabinet can be recycled or disposed of in accordance with local regulations.

Packaging

A single cabinet is packed into a double wall box with key and instruction sheet.

Product	Packed	Qty. per	Ind. Weight	Carton Weight	Measurements
Tekna Ellipse	Carton	1	8.85 kg (19.5 lb)	9.42 kg (20.77 lb)	505 x 415 x 380 mm (19.9 x 16.3 x 8.1 in)
Cabinet Pallet	Standard Pallet	40	406.80 kg (896.84 lb)		1300 x 1000 x 2050 mm (51.2 x 39.4 x 80.7 in)



Kennedy Hygiene Products Limited

Brookside, Uckfield, East Sussex, United Kingdom TN22 1YA

T +44 (0) 1825 768141 F +44 (0) 1825 768143 E sales@kennedy-hygiene.com

<https://kennedy-hygiene.com/>