

# SLIMAIR GEL DISC

## TECHNICAL SPECIFICATIONS

RANGE	PRODUCT CODE	SPEC SHEET NO./ISS	MSDS NO.
Air Freshening	GEL AFR SLM	190-7507/ISS A	See table below

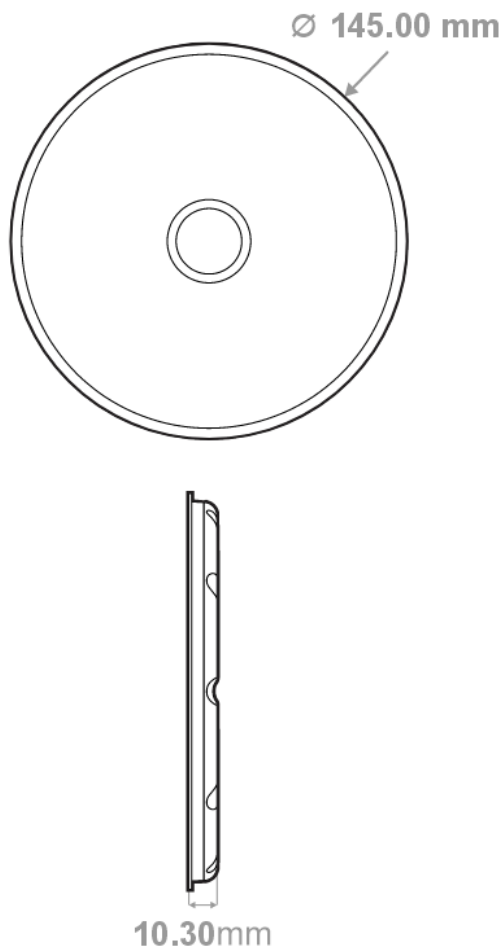

### FEATURES

- Odour-neutralising gel fragrance disc for SlimAir
- Patent-pending design with large surface area for maximum delivery of fragrance
- Continuous, powerful fragrance release for up to 60 days
- Temperature-stable, humidity-resistant gel evaporates at a steady rate irrespective of environmental conditions
- Available in 5 different fragrances ranging from fresh, cool tones to fruity and floral notes

### COMPATIBLE UNITS

(NOT INCLUDED)

SPEC SHEET NO.	DESCRIPTION	PART CODE
190-7506	SlimAir	AFR SLM ELP

### MATERIAL SAFETY DATA SHEETS (MSDS)

MSDS NO.	VARIANT	PART CODE
190-1056	SlimAir Gel – Horizon	GEL AFR SLM HRI
190-1057	SlimAir Gel – Sunrise	GEL AFR SLM SUN
190-1058	SlimAir Gel – Solstice	GEL AFR SLM SOL
190-1059	SlimAir Gel – Drift	GEL AFR SLM DRI
190-1060	SlimAir Gel - Cloudburst	GEL AFR SLM CLO

### MATERIALS

Outer dish made of HDPE. Dish filled with fragrance gel and sealed with polypropylene film.

Full chemical details are given in the material safety data sheet (MSDS).

### PACKING

Store gel discs in a cool, dark place.

Dispose of empty dishes in accordance with local regulations.

PRODUCT	PACKING	QTY	DIMENSIONS	NET WEIGHT	GROSS WEIGHT
SlimAir – Gel	Carton	12	158x158x128 mm	0.076 kg	0.960 kg