

SLIM AIR

TECHNICAL SPECIFICATIONS

RANGE	PRODUCT CODE	SPEC SHEET NO./ISS	MSDS NO.
Air Freshening	AFR SLM ELP	190-7506/ISS B	N/A

FEATURES

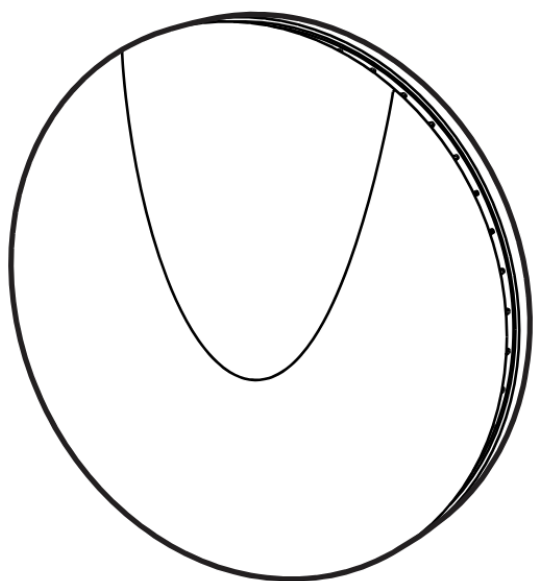

- Passive air freshener ideal for washrooms and toilet cubicles
- Fixes to wall or door using double-sided adhesive pads or screws (both provided)
- Slim, compact design allows unit to be installed in small or narrow spaces
- Adjustable cover for full or partial airflow depending on room or cubicle size
- No liquid means unit can be mounted at any angle
- Accommodates our range of odour-neutralising, temperature-stable resin fragrance discs
- Consumable lasts up to 60 days before replacement
- Patented fragrance disc designed to deliver maximum freshness
- Cover opens with standard Kennedy key
- No batteries, electricity, or programming required

FINISHES



WHITE



OBSIDIAN

CONSUMABLES

(NOT INCLUDED)

SPEC SHEET NO.	DESCRIPTION	PART CODE
190-7507	SlimAir Gel – Horizon	GEL AFR SLM HRI
190-7507	SlimAir Gel – Sunrise	GEL AFR SLM SUN
190-7507	SlimAir Gel – Solstice	GEL AFR SLM SOL
190-7507	SlimAir Gel – Drift	GEL AFR SLM DRI
190-7507	SlimAir Gel – Cloudburst	GEL AFR SLM CLO

MATERIALS

Dispenser made primarily from recycled polypropylene.
Recycled polypropylene is 89% of total material used.
Dispenser can be recycled or disposed of in accordance with local regulations.

DIMENSIONS

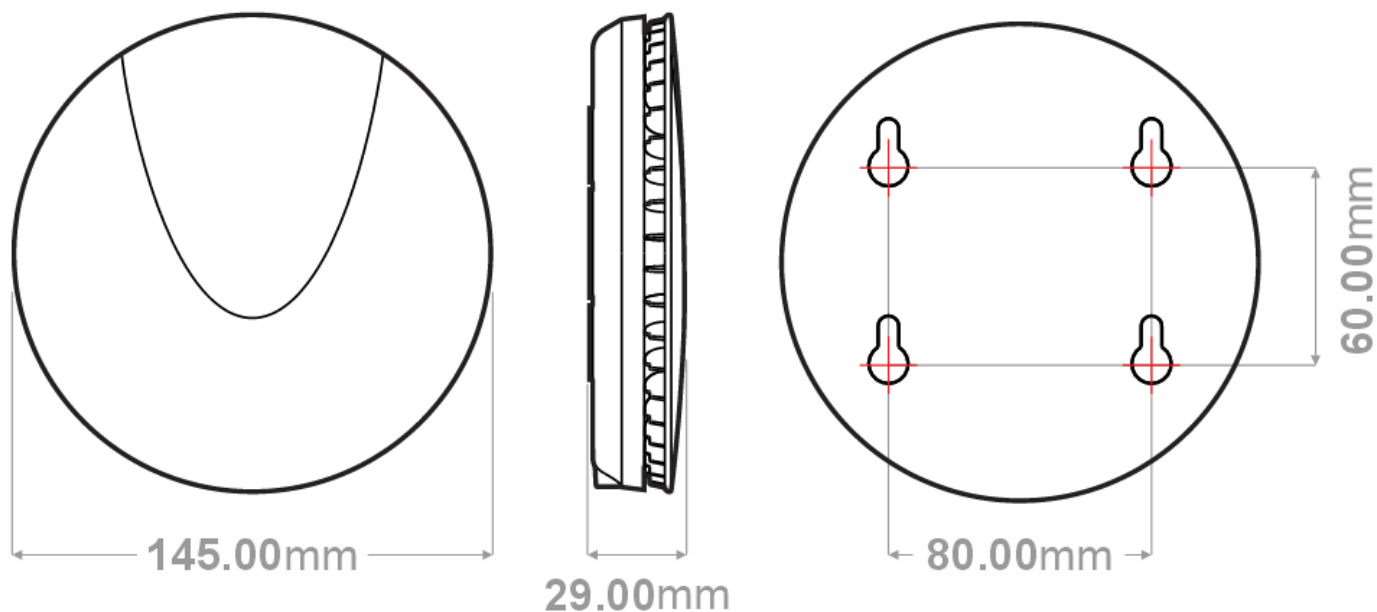

Dimensions above are shown with the cover in the closed position. Dispenser depth in the open position: 34 mm.

PACKING

Individual units are packed in a polyethylene bag with a fixing kit. Four units and one operating/installation instruction sheet per carton.

PRODUCT	PACKING	QTY	DIMENSIONS	NET WEIGHT	GROSS WEIGHT
Slim Air	Carton	4	148x156x156mm	0.089 kg	0.567 kg