

# Sigma Ellipse

Dual roll toilet paper dispenser



## Range

Toilet tissue

## Product Code

TSD SIG ELP

Sigma Ellipse is a dual roll toilet paper dispenser which ensures continuity of paper supply and provides high volume in a compact unit. Sigma Ellipse is ideal for low to medium traffic environments, it accommodates any toilet roll with a core diameter between 28 and 45 mm (1.1 - 1.7 in) and with an external diameter up to 140 mm (5.5 in), and can also accommodate coreless toilet rolls. The unit incorporates intelligent features for service such as a special shield which automatically prevents access to the new toilet roll until the original roll is finished and so reduces paper consumption.

Sigma Ellipse also includes the signature translucent elliptical front insert to show when a refill is required, and a removable braking system which aids consumable control and minimises waste. The unit is also available with a selection of customized inserts and in Kennedy's range of attractive finishes<sup>1</sup>.

## Finishes available

- Arctic White
- Designer Grey
- Chrome

## Customised insert designs available

- White
- Turquoise
- Red
- Beige
- Metal
- Carbon
- Wood
- Water drops

<sup>1</sup> Customised inserts are available with the Arctic white finish. Designer and chrome finishes come with a black insert.

## Benefits

### Control of consumables

- A special shield automatically prevents access to the new roll until the original roll is finished
- Removable braking system means minimal waste

### Ease of service

- Hinged cover for convenience and speed of service
- Practical inspection window shows when a refill is required
- One security key for the whole Kennedy range
- Angled top of dispenser to prevent cigarette burn damage

### End user satisfaction

- Hygienic full cover offering tissue protection
- Serrated paper tear-off from either side of the unit



INTEGRATED HYGIENE SOLUTIONS

# Technical Specifications

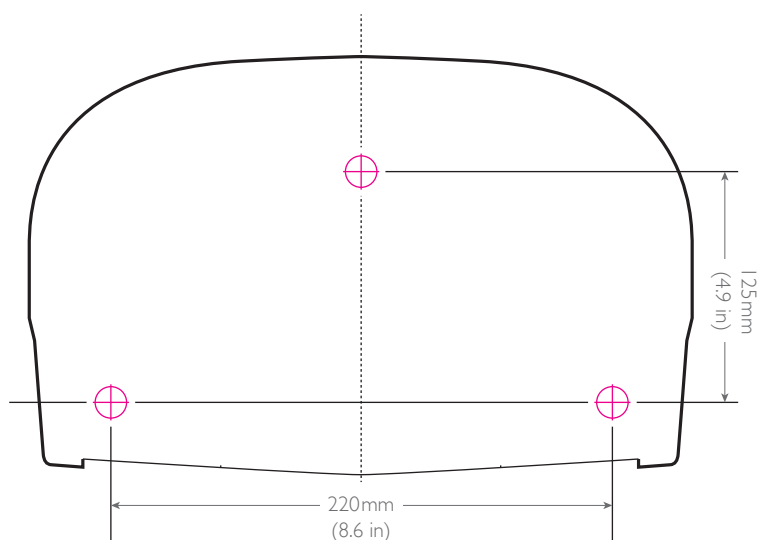
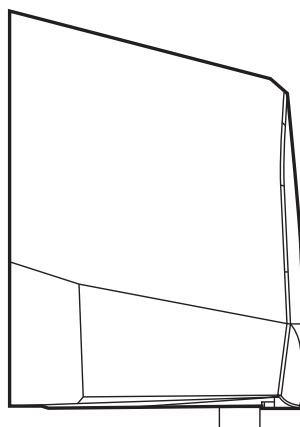
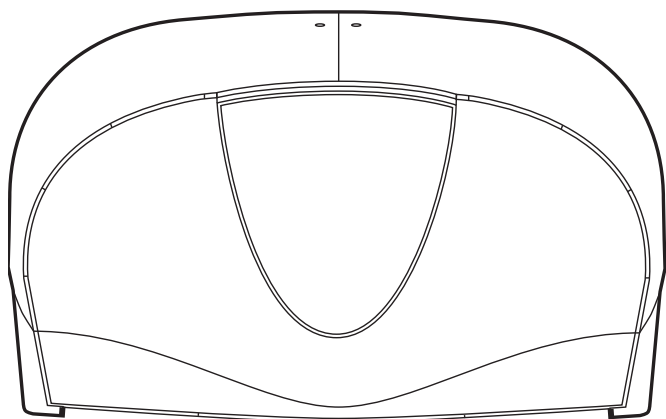

## HEIGHT

197mm (7.7 in)

## WIDTH

310mm (12.2 in)

## DEPTH

143mm (5.6 in)

## ⊕ FIXING POINTS

∅ : 6mm (0.2 in)

## Consumables

- Accepts range of standard toilet tissue rolls up to 140 mm (5.5 in) O/D and 115 mm (4.5 in) depth
- Accepts core diameters 28 – 46 mm (1.1 - 1.7 in) and coreless toilet rolls

## Materials

Constructed from ABS and other engineering thermoplastics. Dispenser can be recycled or disposed of in accordance with local regulations.

## Packaging

Individual units packed in polybags with cardboard dividers in between them.

Product	Pallet type	Quantity per pallet	Packed	Quantity per carton	Weight individual	Weight of carton	Measurement carton dimensions
Sigma Elipse	Standard	240	Carton	4	0.82kg (1.8 lb)	3.85kg (8.5 lb)	600 x 320 x 220 mm (23.6 x 12.6 x 8.6 in)



**Kennedy Hygiene Products Limited**

Brookside, Uckfield, East Sussex, United Kingdom TN22 1YA

**T** +44 (0) 1825 768141 **F** +44 (0) 1825 768143 **E** sales@kennedy-hygiene.com

<https://kennedy-hygiene.com/>