

Seatsan Ellipse Auto

No-touch dispenser for toilet seat sanitising foam



Range

Sanitising dispensers

Product Code

TSS ELP ASN

Seatsan Ellipse Auto provides an ultra-hygienic solution for toilet seat sanitising. Thanks to its highly energy efficient electronic module, the automatic dispenser takes just two individual D-Cell batteries to service up to 85 bottles (of 800 ml each) which means that your running costs are kept extremely low.

The ultra-economical foam uses 30% less consumable than a comparable fluid sanitiser and kills 99.99% of bacteria found on toilet seats. The consumable also conforms to European bacterial and fungicidal standards.

Finishes available

- White
- Designer Grey
- Chrome

Customised insert¹ designs are available in 8 options:

- White
- Turquoise
- Red
- Beige
- Metal
- Carbon
- Wood
- Water drops

Benefits

Maximum hygiene

- Electronic no-touch unit for ultimate hygiene
- Foam meets European Standards EN 1275 and EN 1040
- Bactericide kills Staphylococcus aureus, Pseudomonas aeruginosa and Candida albicans

End user satisfaction

- Smooth dispensing foam alleviates irritating mis-sprays
- Flash-drying enables immediate toilet use

Reliability & durability

- Optimized electronic module to reduce battery consumption and running costs
- Straightforward design and use of highly durable ABS material
- Secure locking system to deter theft and guarantee content integrity
- Non-drip patented pump mechanism for sanitising foam

Ease of service

- Low battery indicator LED on front cover
- Error-proof refill loading feature
- Practical inspection window shows when a refill is required



INTEGRATED HYGIENE SOLUTIONS

¹ Customised inserts are available with the Arctic white finish. Designer grey and chrome finishes come with a black insert.

Technical Specifications

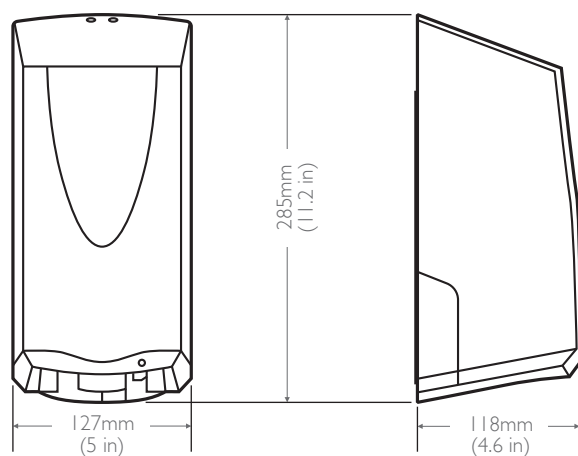

HEIGHT

285 mm (11.2 in)

WIDTH

127 mm (5 in)

DEPTH

118 mm (4.6 in)

Consumables

800ml / 2000 dose toilet seat sanitising foam.

Materials

Constructed fully from recyclable thermoplastics.

Packaging

Individual units are packed in a polythene bag. Four units and one installation/operating instruction sheet are packed per box.

Product	Packed	Quantity per	Weight	Measurements
Seatsan Ellipse Auto	Carton	4	3.6 kg (8 lb)	530 x 290 x 140 mm (20.9 x 11.4 x 5.5 in)



Kennedy Hygiene Products Limited

Brookside, Uckfield, East Sussex, United Kingdom TN22 1YA

T +44 (0) 1825 768141 F +44 (0) 1825 768143 E sales@kennedy-hygiene.com

<https://kennedy-hygiene.com/>