

Savona Ellipse

Liquid soap dispenser



Range

Soap dispensers

Product Code

SPD SAV ELP

The Savona Ellipse is a classically designed liquid soap dispenser suitable for all hand washing environments. This 1 litre soap dispenser is available in both cartridge and direct fill versions and is built for service. Robust and reliable, it has strong features for both service and hygiene. Savona Ellipse is available with a broad range of consumables from regular, cosmetic and anti-bacterial soaps to sanitising gel.

Finishes available

- White
- Designer Grey
- ⊕ Chrome
- Satin

Customised insert¹ designs are available in 8 options:

- White
- Turquoise
- Red
- Beige
- Metal
- Carbon
- Wood
- Water drops

Benefits

Maximum hygiene

- Each cartridge comes with its own nozzle ensuring germ/blockage-free replacement
- Soap has no contact with the unit and comes directly from nozzle to hand
- Patented one-way valve prevents soap from returning to the cartridge

Reliability & durability

- Straightforward design and use of highly durable material
- Non-drip patented pump mechanism
- Locking system to deter theft and guarantee content integrity

End user satisfaction

- Range of versatile soap lotions suitable for various environments
- Push or pull operation options

Ease of service

- Hinged cover for operator convenience and speed of service
- Practical inspection window shows when a refill is required
- One security key for the whole Kennedy range



INTEGRATED HYGIENE SOLUTIONS

¹ Customised inserts are available with the Arctic white finish. Designer grey and chrome finishes come with a black insert.

Technical Specifications

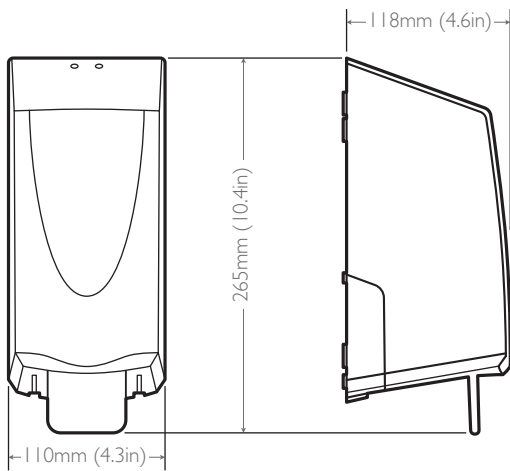

HEIGHT

265 mm (10.4 in)

WIDTH

110 mm (4.3 in)

DEPTH

118 mm (4.6 in)

Consumables

- Kennedy Anti-bacterial Soap Hand Lotion 1L
- Kennedy Cosmetic Soap Hand Lotion 1L
- Kennedy Hand Sanitising Hand Gel 1L
- Kennedy Regular Soap Hand Lotion 1L

Materials

Constructed from recyclable thermoplastics.

Packaging

Individual units are packed in a polythene bag with a fixing pack. Twelve units and one installation/operating instruction sheet are packed in a carton. Individual weight of unit: 460 g

Product	Packed	Quantity per carton	Weight per carton	Measurements per carton
Savona Ellipse	Carton	12	6 kg (13.2 lb)	496 x 336 x 241 mm (19.5 x 13.2 x 9.5 in)



Kennedy Hygiene Products Limited

Brookside, Uckfield, East Sussex, United Kingdom TN22 1YA

T +44 (0) 1825 768141 **F** +44 (0) 1825 768143 **E** sales@kennedy-hygiene.com

<https://kennedy-hygiene.com/>