



**Kennedy**

CLEANER BY DESIGN

Kennedy Hygiene Products Limited  
Brookside, Uckfield,  
East Sussex, TN22 1YA  
United Kingdom  
Telephone: +44 (0)1825 768141  
Fax: +44 (0)1825 768143  
e-mail: sales@kennedy-hygiene.com  
Website: www.kennedy-hygiene.com

## PRODUCT SPECIFICATION SHEET

### SAVONA ELLIPSE AUTOMATIC - FOAM SOAP DISPENSER

KHP Part No: **SPD ELP AFO**

#### DESCRIPTION

- A dispenser delivering foam soap, automatically to the hand without contact
- The dispenser utilises our standard 800ml foam consumable
- Cover opens at the top using the standard Kennedy key (provided)
- Window allows for verification of remaining contents
- The dispenser is screwed to the wall using 3 screws (provided in the fixing pack)
- Screw positions are identical to the Savona range of soap dispensers
- Minimum installation height of 20cm above sink or work surface
- The pump "module" is a self contained, sealed unit. Powered by 2 x "D-Cell" (LR20) batteries
- The battery enclosure is secured using the standard Kennedy key
- Each dispenser is supplied with a re-useable pump, which delivers a nominal 0.40ml per dose
- Battery life is in excess of 70,000 operations (on 2 batteries).

#### DIMENSIONS

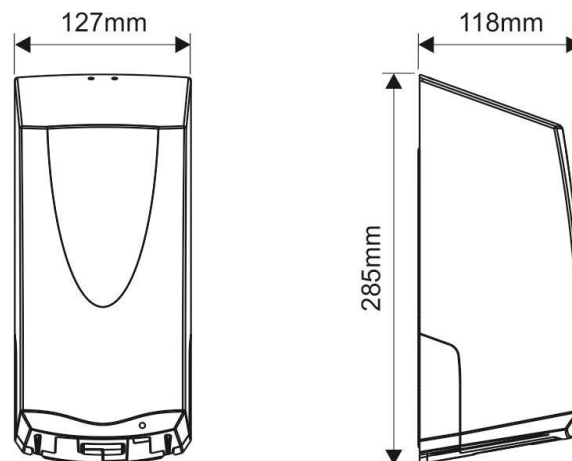

#### MATERIALS

Constructed mainly from recyclable thermoplastics.

#### PACKAGING

Individual units are packed in a polythene bag with a fixing pack.  
4 units and one installation/operating instruction sheet are packed per box.

Individual weight of unit: 877g  
Box size: 523 x 288 x 133mm  
Total weight: 3.6kg

**155-1808 PSS - SPD ELP AFO (ENG) [Iss-1]**



EMS 53617



FM 34822