

Savona Ellipse Auto Foam

Electronic no-touch foam soap dispenser



Range

Soap dispensers

Product Code

SPD ELP AFO

The Savona Ellipse Auto Foam provides an ultra-hygienic solution for hand washing. It is available in both cartridge and direct fill versions and is built for service. Designed for all hand washing environments, the dispenser has a large 800 ml/ 2000 dose cartridge and incorporates several service-friendly features.

Thanks to its highly energy efficient electronic module, this soap dispenser takes just 2 individual D-Cell batteries to service up to 35 x 800 ml bottles of foam soap, which means that running costs are kept extremely low.

Finishes available

- White
- Designer Grey
- ⊕ Chrome
- Satin

Customised insert¹ designs are available in 8 options:

- White
- Turquoise
- Red
- Beige
- Metal
- Carbon
- Wood
- Water drops

Benefits

Reliability & durability

- Optimized electronic module to reduce battery consumption and running costs: up to 35 bottles of 800 ml foam soap per battery set
- Quick-shot dose delivery system
- Single use cartridge or direct fill bottle refills
- Straightforward design and use of highly durable ABS material
- Secure locking system to deter theft and guarantee content integrity
- The pump “module” is a self-contained sealed unit

Ease of service

- Low battery indicator LED on front cover
- Error-proof soap refill loading feature
- Practical inspection window shows when a refill is required
- One security key for the whole Kennedy range

Maximum hygiene

- Electronic no-touch unit for ultimate hygiene
- Patented one-way valve prevents soap from returning to the cartridge



INTEGRATED HYGIENE SOLUTIONS

¹ Customised inserts are available with the Arctic white finish. Designer grey and chrome finishes come with a black insert.

Technical Specifications

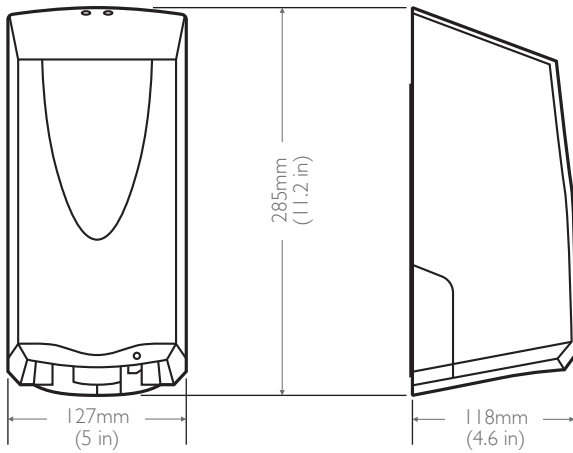

HEIGHT

285 mm (11.2 in)

WIDTH

127 mm (5 in)

DEPTH

118 mm (4.6 in)

Consumables

- Kennedy ECOLABEL foam soap 800ml
- Kennedy foam soap lotion 800ml

Materials

Constructed from recyclable thermoplastics.

Packaging

Individual units are packed in a polythene bag with a fixing pack. Four units and one installation/operating instruction sheet are packed per box. Individual weight of unit: 877g.

Product	Pallet type	Packed	Quantity per carton / pallet	Weight carton	Measurements per carton
Savona Ellipse Auto Foam	Euro	Carton	4 / 240	3.6 kg (7.9 lb)	523 x 288 x 133 mm (20.6 x 11.3 x 5.3 in)



Kennedy Hygiene Products Limited

Brookside, Uckfield, East Sussex, United Kingdom TN22 1YA

T +44 (0) 1825 768141 F +44 (0) 1825 768143 E sales@kennedy-hygiene.com

<https://kennedy-hygiene.com/>