

Maxima Ellipse

Reserve toilet roll dispenser



Range

Toilet tissue

Product Code

TSD MAX ELP

Maxima Ellipse is a reserve roll toilet roll dispenser ideal for high traffic environments. The unit accommodates any toilet roll with a core diameter of 56 – 62 mm (2.2 - 2.4 in) and with an external diameter up to 260 mm (10.2 in). It incorporates intelligent features for service such as a special shield which automatically prevents access to the new roll until the original roll is finished. Thanks to this feature, paper savings of up to 20% can be achieved.

Maxima Ellipse also includes features such as a practical inspection window to show when a refill is required and a removable braking system which aids consumable control and minimizes waste. Maxima Ellipse is available with a selection of customised inserts and in Kennedy's range of attractive finishes¹.

Finishes available

- Arctic White
- Chrome
- Designer Grey
- Satin

Customised insert designs available

- White
- Turquoise
- Red
- Beige
- Metal
- Carbon
- Wood
- Water drops

¹ Customised inserts are available with the Arctic white finish. Designer and chrome finishes come with a black insert.

Benefits

Control of consumables

- A special shield automatically prevents access to the new roll until the original roll is finished
- Removable braking system means minimal waste
- Tray prevents premature use of full roll
- Tray returns to start position automatically when cover is opened

Ease of service

- Hinged cover for convenience and speed of service
- Practical inspection window shows when a refill is required
- One security key for the whole Kennedy range
- Angled top of dispenser to prevent cigarette burn damage
- Roll held on braked mandrel, giving smooth controlled operation

- Cutting teeth around bottom edges assist tearing of paper.
- Dispenser can be sited on left or right hand side of cubical.

End user satisfaction

- Hygienic full cover offering tissue protection
- Serrated paper tear-off from either side of the unit



INTEGRATED HYGIENE SOLUTIONS

Technical Specifications

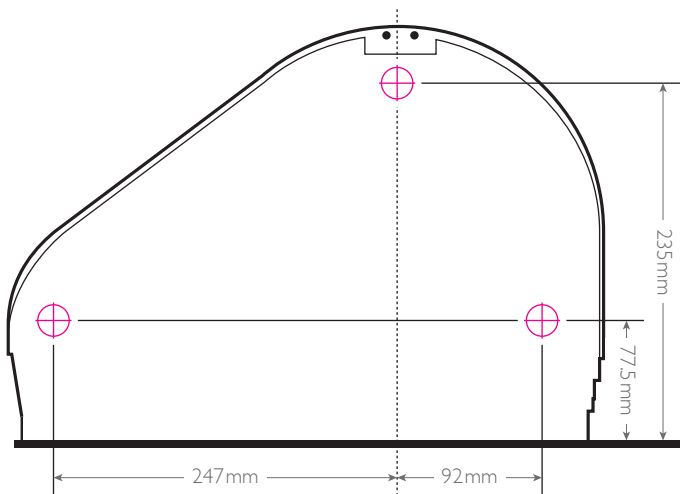
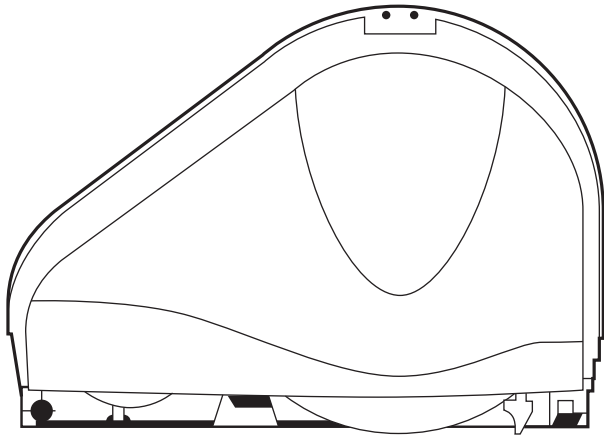

HEIGHT

295mm (11.6 in)

WIDTH

420mm (16.5 in)

DEPTH

135mm (5.3 in)

⊕ FIXING POINTS

∅ : 6mm (0.2 in)

Consumables

- Accepts range of readily available toilet rolls up to ∅ 260 mm (10.2 in) maximum.
- Part used roll ∅ 135 mm (5.3 in) maximum.
- Accepts core diameters 56 – 62 mm (2.2 - 2.4 in).

Materials

Constructed mainly from ABS as well as other engineering thermoplastics, such as Acetal and Polypropylene. Dispenser can be recycled or disposed of in accordance with local regulations.

Packaging

Individual units packed in polybags with cardboard dividers between them.

Product	Pallet type	Quantity per pallet	Packed	Quantity per carton	Weight individual	Weight of carton	Measurement carton dimensions
Maxima Ellipse	Euro	96	Carton	4	1.34kg (2.9 lb)	6.17 kg (13.6 lb)	560 x 430 x 310 mm (22.1 x 16.9 x 12.2 in)



Kennedy Hygiene Products Limited

Brookside, Uckfield, East Sussex, United Kingdom TN22 1YA

T +44 (0) 1825 768141 F +44 (0) 1825 768143 E sales@kennedy-hygiene.com

<https://kennedy-hygiene.com/>