

Ladybin

Contemporary feminine hygiene unit



Range

Feminine Hygiene

Product Code

LAD BIN HOS

Ladybin is a contemporary 23-litre feminine hygiene unit which offers maximum waste holding capacity with minimal floor obstruction. It can be used for both liner and bin exchange service and is available in manual and electronic no-touch versions.

Ladybin is a robust unit made from high quality materials. It incorporates intelligent features to aid service and promote maximum hygiene, while making the end user experience pleasant.

Finishes available

- White
- Designer Grey

Benefits

Ease of service

- Convenient handle, allowing four units to be carried at one time
- Wall-mount bracket supplied with every unit to ease floor cleaning

Maximum hygiene

- Simple lines and smooth surfaces minimize dirt and dust traps
- Flap easily removed for cleaning
- Reinforced drawstring "easy closing" bin liners
- Germicidal powder sachets inhibit bacterial growth and prevent malodours

End user satisfaction & image

- No visual contact with waste due to the angled flap
- Enhances the image of any washroom environment



INTEGRATED HYGIENE SOLUTIONS

Technical Specifications

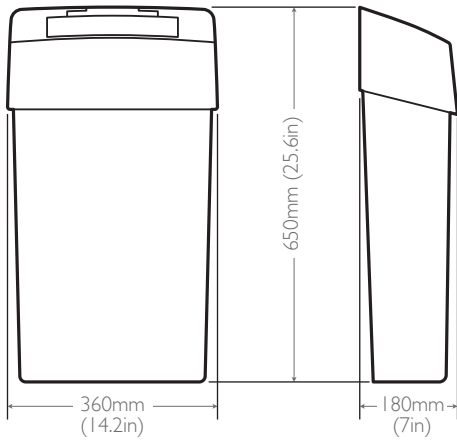

HEIGHT

650 mm (25.6 in)

WIDTH

360 mm (14.2 in)

DEPTH

180 mm (7 in)

Consumables

Reinforced drawstring "easy closing" bin liners

- Robust 70 microns thick bags with unbreakable strings

Germicidal powder sachets

- Inhibit microbial growth and prevent offensive odour

Protective lid inserts

- Protect against soiling and aid super-fast and hygienic service

Materials

Constructed from ABS. Dispenser can be recycled or disposed of in accordance with local regulations.

Packaging

Each Ladybin is packed fully assembled. Individual units are packed in a polythene bag.

Two units are packed in a carton. Individual product weight: 3.2 kg (7 lb).

Product	Pallet	Packed	Quantity	Weight	Measurements
Ladybin	Euro	Carton	2	6.75 kg (14.9 lb)	670 x 370 x 387 mm (26.4 x 14.6 x 14.6 in)
		Pallet	36	138 kg (304.2 lb)	1200 x 800 x 2140 mm (47.3 x 31.5 x 84.3 in)



Kennedy Hygiene Products Limited

Brookside, Uckfield, East Sussex, United Kingdom TN22 1YA

T +44 (0) 1825 768141 F +44 (0) 1825 768143 E sales@kennedy-hygiene.com

<https://kennedy-hygiene.com/>