

# Ladybin Auto

Contemporary automatic feminine hygiene unit



## Range

Feminine Hygiene

## Product Code

LAD BIN HOS AUT

Ladybin Auto is a 23-litre no-touch feminine hygiene unit which offers maximum waste holding capacity with minimal floor obstruction. It can be used for both liner and bin exchange service and is available in manual and electronic no-touch versions.

It is an automatic robust unit made from high quality materials. It incorporates intelligent features to aid service and promote maximum hygiene, while making the end user experience pleasant.

## Finishes available

- White
- Designer Grey

## Benefits

---

### Ease of service

- Convenient handle, allowing four units to be carried at one time
- Wall-mount bracket supplied with every unit to ease floor cleaning

### Maximum hygiene

- Available in electronic version for no-touch operation
- Simple lines and smooth surfaces minimize dirt and dust traps
- Flap easily removed for cleaning
- Reinforced drawstring "easy closing" bin liners
- Germicidal powder sachets inhibit bacterial growth and prevent malodours

### End user satisfaction & image

- No visual contact with waste due to the angled flap
- Enhances the image of any washroom environment



INTEGRATED HYGIENE SOLUTIONS

# Technical Specifications

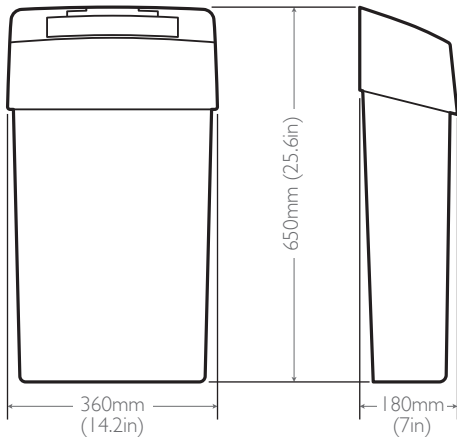

## HEIGHT

650 mm (25.6 in)

## WIDTH

360 mm (14.2 in)

## DEPTH

180 mm (7 in)

## Consumables

- The unit operates with 2 X D cell batteries
- Reinforced drawstring “easy closing” bin liners
- Germicidal powder sachets that inhibit microbial growth and prevent offensive odour
- Protective lid inserts – protect against soiling and aid super-fast and hygienic service

The consumables are not included.

## Materials

Constructed from ABS. Dispenser can be recycled or disposed of in accordance with local regulations.

## Packaging

Each Ladybin is packed fully assembled. Individual units are packed in a polythene bag.

Two units are packed in a carton. Individual product weight: 3.2 kg (7 lb).

Product	Pallet	Packed	Quantity	Weight	Measurements
Ladybin Auto	Euro	Carton	2	8 kg (17.7 lb)	670 x 370 x 387 mm (26.4 x 14.6 x 14.6 in)
		Pallet	36	164 kg (361.6 lb)	1200 x 800 x 2140 mm (47.3 x 31.5 x 84.3 in)



**Kennedy Hygiene Products Limited**

Brookside, Uckfield, East Sussex, United Kingdom TN22 1YA

T +44 (0) 1825 768141 F +44 (0) 1825 768143 E [sales@kennedy-hygiene.com](mailto:sales@kennedy-hygiene.com)

<https://kennedy-hygiene.com/>