

Intima Mini

Market leading feminine hygiene unit



Range

Feminine Hygiene

Product Code

LAD BIN IMI PDL

Intima Mini pedal is an aesthetically pleasing, robust and compact feminine hygiene unit. Available in 15-litre capacity, it has modern design that takes up minimal floor space. It can be used for liner and bin exchange service.

It incorporates exceptional functionality, quality and intelligent features to aid service and promote maximum hygiene, while making the end user experience pleasant.

Finishes available

White

Designer Grey

Chrome

Satin

Benefits

Ease of service

- Innovative reversible cover eases location in cubicle
- Designed throughout to minimise dirt traps
- Flexible liner system for easy liner fitting

Maximum hygiene

- Foot-pedal model for hands-free operation
- Snap in/out protective flap insert that protects against soiling and aids fast hygienic service
- Reinforced drawstring "easy-closing" bin liners
- Germicidal powder sachets inhibit bacterial growth and prevent malodours

End user satisfaction & image

- No visual contact with waste due to the angled flap
- Enhances the image of any washroom environment



INTEGRATED HYGIENE SOLUTIONS

Technical Specifications

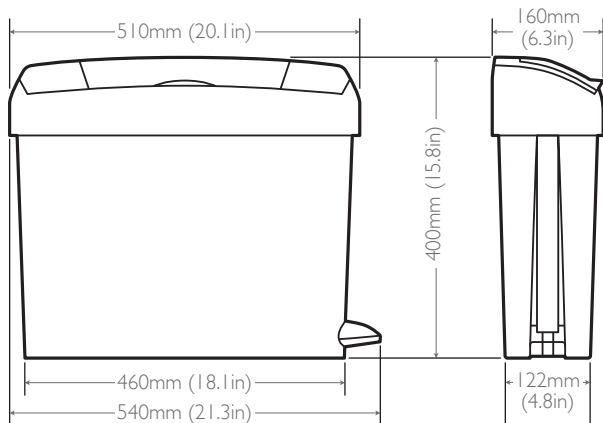

HEIGHT

400 mm (15.8in)

WIDTH

540 mm (21.3in)

DEPTH

160 mm (6.3 in)

Consumables

- Reinforced drawstring "easy closing" bin liners - 70 microns thick bags with unbreakable strings
- Germicidal powder sachets that inhibit microbial growth and prevent offensive odour
- Protective lid inserts – easy to attach and remove, protect against soiling and aid fast and hygienic service

Materials

Constructed predominantly from ABS. Dispenser can be recycled or disposed of in accordance with local regulations.

Packaging

Each unit is packed fully assembled. Individual units are packed in a polythene bag. Two units are packed in a carton. Individual product weight: 2.4 kg (5.3 lb).

Product	Pallet	Packed	Quantity	Weight	Measurements
Intima Mini	Euro	Carton	2	5.3 kg (11.7 lb)	550 x 340 x 420 mm (21.6 x 13.4 x 16.5 in)
		Pallet	40	110 kg (242.5 lb)	1200 x 800 x 2230 mm (47.3 x 31.5 x 87.8 in)



Kennedy Hygiene Products Limited

Brookside, Uckfield, East Sussex, United Kingdom TN22 1YA

T +44 (0) 1825 768141 **F** +44 (0) 1825 768143 **E** sales@kennedy-hygiene.com

<https://kennedy-hygiene.com/>