



**Kennedy**

WASHROOM HYGIENE SYSTEMS

Kennedy Hygiene Products Limited  
Brookside, Uckfield  
East Sussex, TN22 1YA  
United Kingdom  
Telephone: +44 (0)1825 768141  
Fax: +44 (0)1825 768143  
e-mail: sales@kennedy-hygiene.com  
Website: www.kennedy-hygiene.com

## PRODUCT SPECIFICATION SHEET

### INTEGRA CABINET

**KHP PART No. CAB ITG UNP  
CAB ITG MIR (mirror)  
CAB ITG (\*) variants**

### DESCRIPTION

- Strong transparent ABS towel bin
- Designed to be used with 40m long standard towel, up to a max width of 270mm
- Tough, long lasting mechanism with steel gears
- Self-supporting lid with tamper proof snap lock
- Minimum maintenance required, with easy availability of spare parts
- Left/right hand lock. Locks uses key common with other products in the range.

### DIMENSIONS

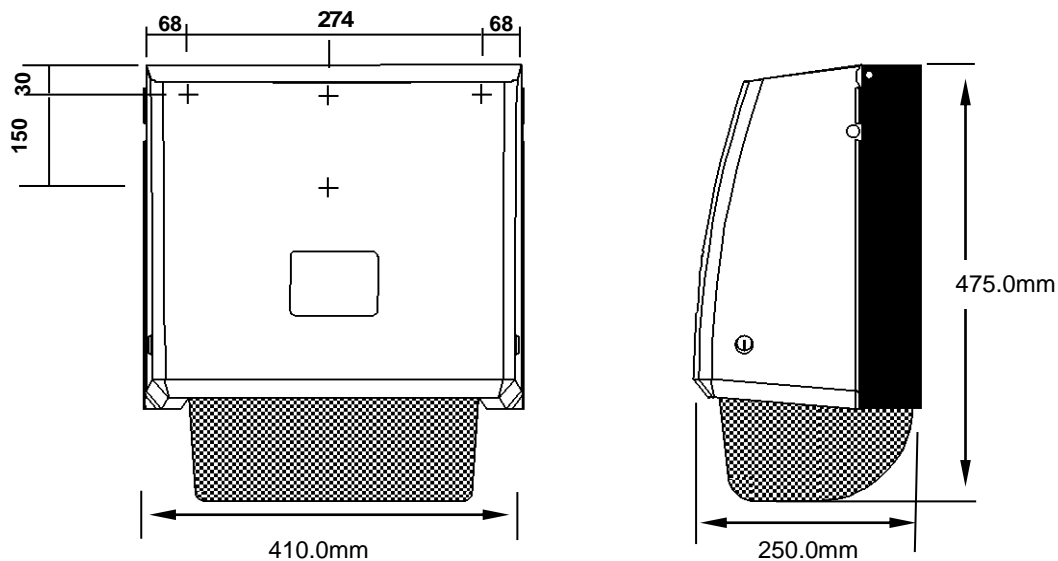

### MATERIALS

Backplate made from steel and painted black. Front cover and various internal parts made from ABS and other engineering thermoplastics.

### PACKAGING

2 cabinets are packed into a double wall box with key and instruction sheet.  
Box dimensions: 52cm x 41cm x 39cm  
Individual weight: 6.5kg  
Total weight: 15kg

PSS (CAB ITG) May 2007



EMS 53617



FM 34822