

Integra Ellipse

Best-selling cotton roll towel (CRT) cabinet



Range

Hand drying

Product Code

CAB ITG ELP

Integra Ellipse is ideal for even the busiest washroom. It is a highly robust and reliable hand drying system. The Integra Ellipse provides hygiene, service and environmental benefits while delivering a 'comfort like home' hand drying experience for the end user.

The consumable used with Integra Ellipse, the cotton towel, is a natural biodegradable product making this cabinet a positive choice for the environment. It delivers 200 portions from a standard 40m towel and is available with a selection of customised inserts as well as in Kennedy's range of attractive finishes. ¹

Finishes available

- Arctic White
- Chrome
- Designer Grey
- Satin

Customised insert designs available

- White
- Turquoise
- Red
- Beige
- Metal
- Carbon
- Wood
- Water drops

¹ Customised inserts are available with the Arctic white finish. Designer grey, chrome and satin finishes come with a black insert.

Benefits

Reliability and durability

- 40-years experience in cabinet engineering
- Proven ultra-robust mechanism
- Lockable cabinet to prevent unauthorised access

Hygiene and image

- Modern design
- Used towel isolated from clean towel

Ease of service

- Instant towel check through transparent reservoir
- Lock can be located on either side to maximise fitting options

Environmentally friendly

- Mechanical operation – no external power source required
- Cotton towels are one and a half times less harmful to the environment than paper equivalents ^{*}
- 100% recyclable components



INTEGRATED HYGIENE SOLUTIONS

* Source ETSA lifecycle analysis study 2007

Technical Specifications

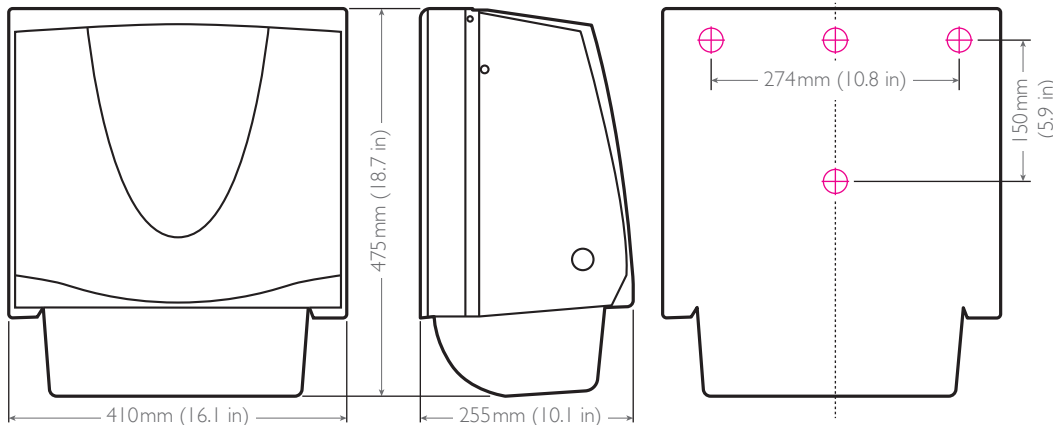

HEIGHT

475mm (18.7 in)

WIDTH

410mm (16.1 in)

DEPTH

255mm (10.1 in)

⊕ FIXING POINTS

Ø : 6mm (0.2 in)

Consumables

40m standard cotton roll towel provides 200 towel portions.

Towel usage/service frequency:

- Medium to high traffic:
 - 4-5 users per cabinet 3 times per day = towel change every 2 weeks
 - 8-10 users per cabinet = weekly towel change

Materials

Backplate made from steel and painted black. Front cover and various internal parts made from ABS and other engineering thermoplastics.

Packaging

Two cabinets are packed into a double wall box with key and instruction sheet.

Product	Packed	Qty. per	Ind. Weight	Carton Weight	Measurements
Integra Ellipse	Carton	2	6.20 kg (13.67 lb)	13.05 kg (28.77 lb)	505 x 415 x 380 mm (19.9 x 16.3 x 8.1 in)
Cabinet Pallet		60	421 kg (132.28 lb)		1300 x 1000 x 2050 mm (51.2 x 39.4 x 80.7 in)



Kennedy Hygiene Products Limited

Brookside, Uckfield, East Sussex, United Kingdom TN22 1YA

T +44 (0) 1825 768141 F +44 (0) 1825 768143 E sales@kennedy-hygiene.com

<https://kennedy-hygiene.com/>