

# Hycare

The ultimate hygienic cotton hand drying cabinet



## Range

Hand drying

## Product Code

CAB HYC

Hycare is a modern, robust and durable cotton roll towel dispenser.

This fully automated towel dispenser with a new sideways operation provides superior hygiene and environmental benefits, and delivers luxurious hand drying experience for the end user.

The two-chambered unit separates the clean and used sections of the towel roll preventing cross contamination. The pre-laundered cotton towel offers excellent absorbency and hygienic standards. It is a natural biodegradable product, making this system a positive choice for the environment.

## Finishes available

White

## Benefits

### Reliability & durability

- Proven ultra-robust mechanism
- Lockable cabinet to prevent unauthorised access
- 40 years' experience in cabinet engineering

### Ease of service

- Easy installation and loading of the towel
- Instant towel check through transparent reservoir
- Automatic retract of used towel

### Hygiene & image

- Sensor-operated for ultimate hygiene
- Clear separation of fresh from used towel
- Distinctive visual appeal
- Compact and modern design

### Environmentally friendly

- Reduced towel wastage
- Sensor operated – no external power source required
- Biodegradable cotton towel\*



INTEGRATED HYGIENE SOLUTIONS

\* Visit <http://kennedy-hygiene.com/green-credentials/>

# Technical Specifications

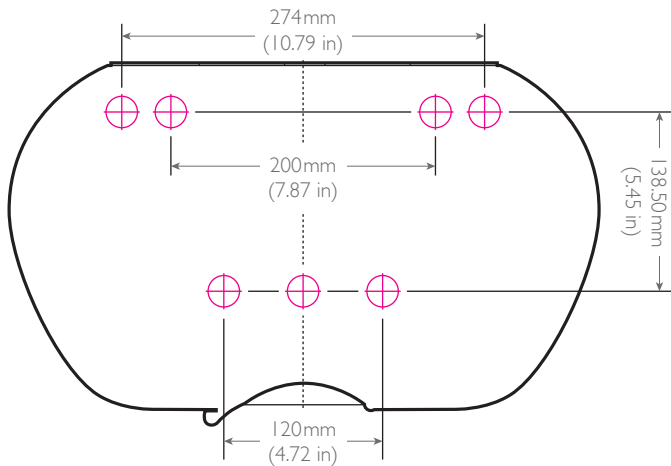
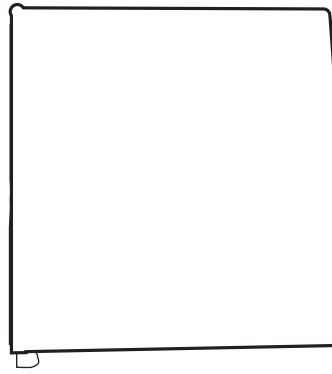
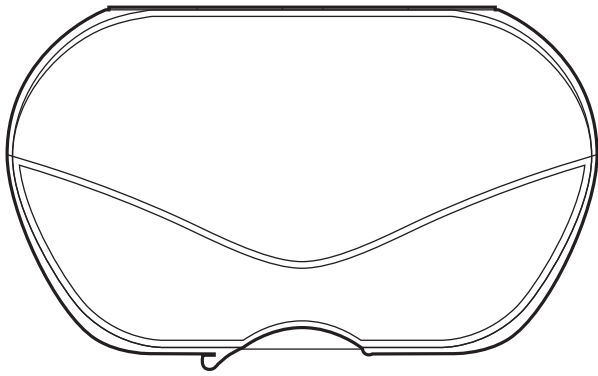

## HEIGHT

259mm (10.20 in)

## WIDTH

448mm (17.64 in)

## DEPTH

251mm (9.88 in)

## ⊕ FIXING POINTS

∅ : 6mm (0.2 in)

## Materials

- Strong transparent POLYCARBONATE cover and base
- Various internal parts made from ABS, steel and other engineering thermoplastics
- Designed to be used with maximum 40m long standard towel, up to a max. width of 200mm
- Replaceable front insert version available
- Tough, long lasting mechanism with steel chain
- Self-supporting lid with tamper-proof snap lock
- Minimum maintenance required
- Front located lock

## Consumables

### Towels

- Maximum 40m standard cotton roller towels
- Towel usage/service frequency: 100 towel portions of 40cm per roll

### Batteries

- Battery pack: 6 x D-Cell
- Battery weight: 0.825kg
- Battery life: 92 towels (up to 40m towel length)

## Packaging

One cabinet is packed into a double wall box with key and instruction sheet.

### Box dimensions

34 x 52.2 x 26.5 cm

### Individual weight

6.62 kg

### Total weight of carton

6.90 kg

### Pallet dimensions

120 x 80 x 185 cm

### Packed type

Standard

### Packed quantity

30



**Kennedy Hygiene Products Limited**

Brookside, Uckfield, East Sussex, United Kingdom TN22 1YA

T +44 (0) 1825 768141

F +44 (0) 1825 768143

E [sales@kennedy-hygiene.com](mailto:sales@kennedy-hygiene.com)