

Bambina

Pedal operated nappy bin



Range

Baby hygiene

Product Code

NAP BIN BAM

Bambina is a 50-litre pedal operated nappy bin with a built-in odour control system. Developed in response to market demand for a robust and aesthetically pleasing pedal operated bin, Bambina incorporates a host of practical service and user friendly features. The unit has a large waste holding capacity while remaining compact, modern and attractive in design. It is pedal operated to ensure maximum hygiene and has a unique built-in odour control system which makes the end-user experience pleasant.

Finishes available

White

Grey

Yellow

Benefits

Ease of service

- Removable hygienic bin protects from soiling / eases cleaning
- Designed throughout to minimise dirt traps

Maximum hygiene

- Foot pedal for handsfree operation
- Removable hygienic bin
- Protects inside of bin from soiling
- Removes for easy bin cleaning

Consumables for extra hygiene

- Nappy bin liners
- Germicidal powder sachets
 - Inhibit microbial growth
 - Prevent offensive odour

End user satisfaction & image

- Built in odour control system
- Large centrally positioned aperture for easy nappy disposal
- Modesty flap ensures waste inside is not visible
- Compact, modern and attractive design



INTEGRATED HYGIENE SOLUTIONS

† Customised inserts are available with the Arctic White finish. Designer Grey and Chrome finishes come with a black insert.
▪ Patented features

Technical Specifications

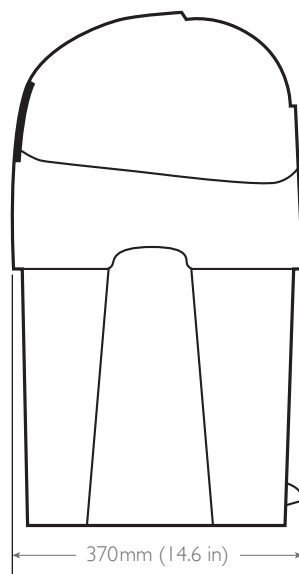
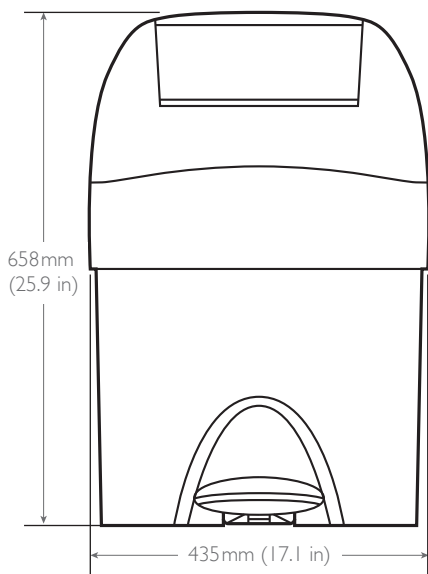

HEIGHT
658mm (25.9 in)

WIDTH
435mm (17.1 in)

DEPTH
370mm (14.6 in)

Consumables

- Nappy bin liners
- Germicidal powder sachets
- inhibit microbial growth
- prevent offensive odour

Materials

Constructed mainly from ABS. Dispenser can be recycled or disposed of in accordance with local regulations.

Packaging

One unit is packed into a double wall carton.

Product	Pallet	Packed	Quantity per	Weight	Measurements
Medina	NA	Carton	1	6kg (13.2lb)	440 x 375 x 530mm (17.3 x 14.7 x 20.8in)
Medina	Standard	Pallet	18	113kg (249.1lb)	1200 x 1000 x 2000mm (47.2 x 39.4 x 78.7in)



Kennedy Hygiene Products Limited

Brookside, Uckfield, East Sussex, United Kingdom TN22 1YA

T +44 (0) 1825 768141 **F** +44 (0) 1825 768143 **E** sales@kennedy-hygiene.com

<https://kennedy-hygiene.com/>