

Baby changing station

Wall mounted horizontal nappy changing unit



Range

Baby hygiene

Product Code

BAB CHA HOR

The baby changing unit is designed for safe and hygienic nappy changing in public washroom areas, whilst providing reliable strength and years of service. Bag hooks located on both ends of the changing table allow the child's nappy bag to be securely hung for easy access, while the second hook is available for a handbag, shopping bag, jacket etc.

Finishes available

● Grey

Benefits

Reliability & durability

- Robust high-density polyethylene construction
- Internal metal skeleton, cannot be dismantled
- Moulded in instruction, no label that can be vandalised or removed
- Developed for the most demanding markets, including the USA
- Heavy duty gas strut for long life

Maximum safety

- Smooth, concave shelf design prevents child from rolling around
- Strong safety strap provides an additional level of child security
- Meets or exceeds ASTM safety requirements
- ADA compliant when properly installed

Ease of use

- Bag hooks on either end of the table
- One-handed opening and closing
- Folds to the wall when not in use
- Universal instruction graphics and safety messages in six languages and Braille

Maximum hygiene

- Microban antimicrobial protection inhibits the growth of odour causing bacteria
- Easy clean crevice-free design
- Built-in liner dispenser



INTEGRATED HYGIENE SOLUTIONS

Technical Specifications

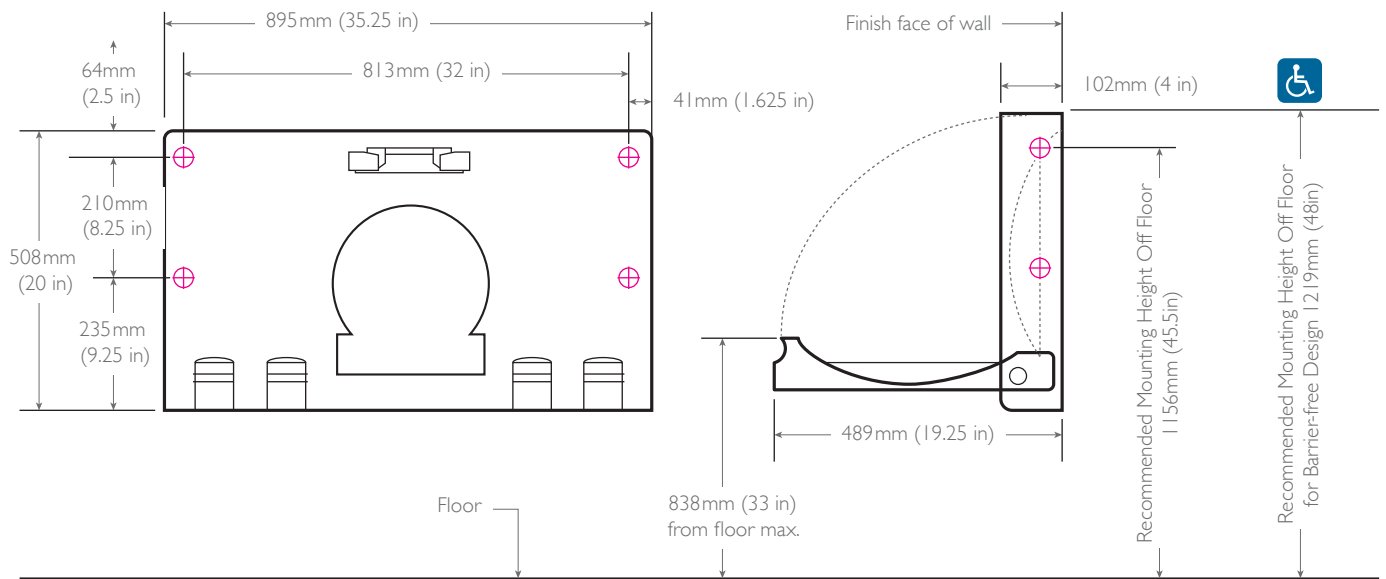

HEIGHT

508mm (20 in)

WIDTH

895mm (35.2 in)

DEPTH

122mm (4.8 in)

⊕ FIXING POINTS

∅ : 6mm (0.2 in)

Consumables

The built-in dispenser can accommodate standard disposable plastic bed liners.

Materials

FDA approved blow-moulded high-density polyethylene with Microban Antimicrobial additive. Reinforced full-length steel-on-steel hinge mechanism, with 11-gauge steel mounting plates and mounting hardware included.

Packaging

One unit is packed into a double wall carton.

Product	Packed	Quantity per	Weight (individual)	Measurements
Baby changing table	Carton	1	7.35kg (16.2lb)	508 × 895 × 122mm (20 × 25.2 × 4.8in)



Kennedy Hygiene Products Limited

Brookside, Uckfield, East Sussex, United Kingdom TN22 1YA

T +44 (0) 1825 768141 F +44 (0) 1825 768143 E sales@kennedy-hygiene.com

<https://kennedy-hygiene.com/>