

Activa

Fully programmable urinal & WC sanitiser



Range

Sanitising dispensers

Product Code

URS AVA

The Activa provides a total solution for the effective prevention of scale, control of bacterial growth and malodours in urinals, WCs and their associated piping. The unit is available in Kennedy's full range of attractive finishes. At the heart of the system is Bio-active™, an advanced and highly effective 3 in 1 sanitising fluid based on natural ingredients. Bio-active neutralises malodour by preventing the formation of scale and controlling the growth of harmful bacteria.

Finishes available

White

Designer Grey

Chrome

Benefits

Hygiene and image

- A total solution for effective prevention of scale and control of bacterial growth and malodours in urinals, WCs and their associated piping
- It works with Bio-active™ - an advanced and highly effective 3 in 1 sanitising fluid based on natural ingredients
- Its state-of-the-art design makes it both flexible and practical solution

Ease of programming and service

- Large external LCD screen* for easy viewing and fast service
- Integral minimal keypad for straightforward program selection: just scroll and select - Activa's intuitive software does the rest

- Range of personalized settings to suit any location and quick program change
- Unrestricted refill usage range – 2 to 24 per year
- Practical service intervals shown in weeks, with optional low battery alarms – visible or audible
- Optional screensaver – choose screensaver to hide days left to next service
- Error-proof, easy loading refill

End user satisfaction

- Maximum efficiency in control of malodours
- A range of optional fixing kits for varying installation needs



Kennedy

INTEGRATED HYGIENE SOLUTIONS

Technical Specifications

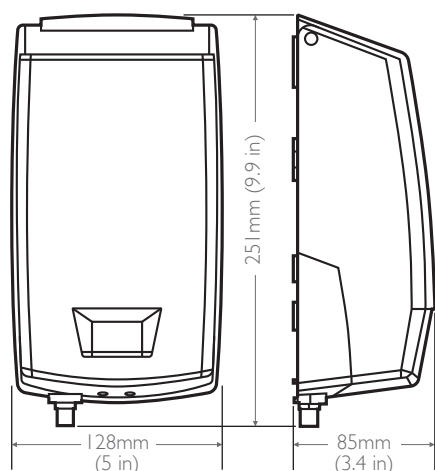

HEIGHT
251 mm (9.9 in)

WIDTH
128 mm (5 in)

DEPTH
85 mm (3.4 in)

Consumables

Kennedy Bio-active™ sanitising fluid

Materials

Constructed from engineering thermoplastics. Dispenser can be recycled or disposed of in accordance with local regulations.

Packaging

Individual units are packed in a polythene bag with fixing pack. Four units are packed in a box with an installation/operating instruction sheet. Individual weight of unit (without batteries): 540g (1.2 lb).

Product	Packed	Quantity per	Weight	Measurements
Activa	Carton	4	2.8 kg (6.2 lb)	260 x 260 x 290 mm (10.2 x 10.2 x 11.4 in)



Kennedy Hygiene Products Limited

Brookside, Uckfield, East Sussex, United Kingdom TN22 1YA

T +44 (0) 1825 768141 F +44 (0) 1825 768143 E sales@kennedy-hygiene.com

<https://kennedy-hygiene.com/>