

PRODUCT SPECIFICATION SHEET

METRO CABINET

**KHP PART No: CAB MCL UNP
CAB MCL MIR (mirror)**

DESCRIPTION

- Steel backplate with ABS cover & sides
- Strong transparent polycarbonate towel bin
- Designed to be used with 20m long towel, width of 210mm max
- Towels dispense length 190mm
- Self-supporting lid with dual locks
- Simple mechanism with divider plate to separate clean from used towel.

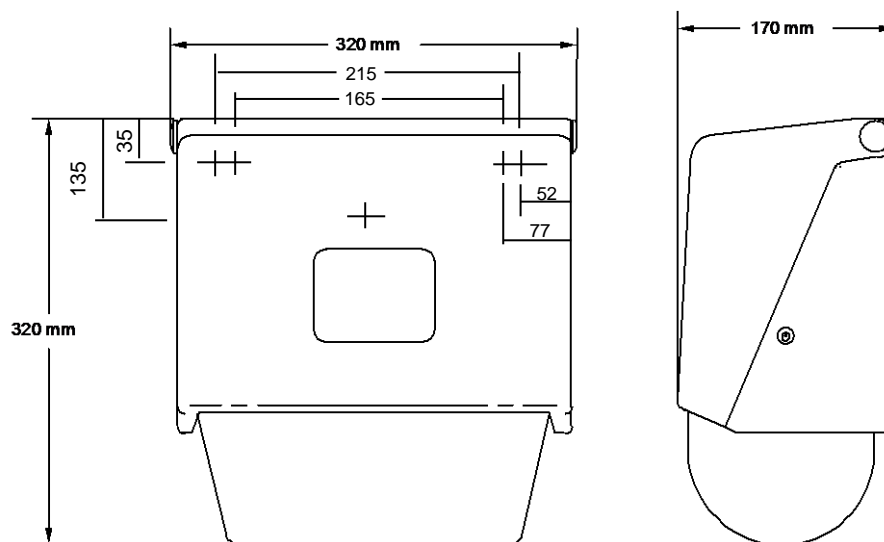

MATERIALS

Cover and side plates made from ABS. Backplate made from steel. Cabinet can be recycled or disposed of in accordance with local regulations.

PACKAGING

Cabinet weight: 3.1kg
Two cabinets are packed in box with fixing pack.
Box size: 33cm x 31.5cm x 35cm
Total weight: 6.7kg