



**Kennedy**

INTEGRATED HYGIENE SOLUTIONS

Kennedy Hygiene Products Limited  
Brookside, Uckfield,  
East Sussex, TN22 1YA  
United Kingdom  
Telephone: +44 (0)1825 768141  
Fax: +44 (0)1825 768143  
email: sales@kennedy-hygiene.com  
Website: www.kennedy-hygiene.com

## PRODUCT SPECIFICATION SHEET

### MAXIMA ELLIPSE TISSUE DISPENSER

**KHP PART No: TSD MAX ELP**

### DESCRIPTION

- Accepts range of readily available jumbo toilet rolls up to Ø260mm max
- Replaceable front insert
- Part used roll Ø135mm max
- Accepts core diameters 56mm – 62mm
- Roll held on braked mandrel, giving smooth controlled operation
- Cutting teeth around bottom edges assist tearing of paper
- Dispenser can be sited on left- or right-hand side of cubicle
- Dampened opening of hinged cover
- Lock acts on 2 independent catches for added security and reliability
- Tray prevents premature use of full roll
- Tray returns to start position automatically when cover is opened.

### DIMENSIONS

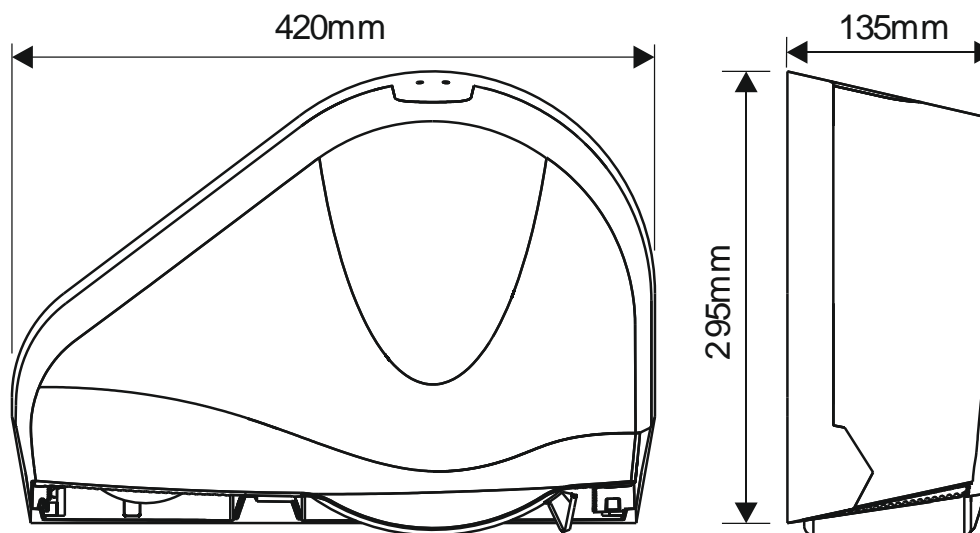

### MATERIALS

Constructed mainly from ABS, as well as other engineering thermoplastics, such as Acetal and Polypropylene. Dispenser can be recycled or disposed of in accordance with local regulations.

### PACKING

Individual units packed in polybags with cardboard dividers in between them.

Individual weight: 1.55kg

4 units packed into carton: 560x430x300mm

Total weight: 6.85kg



EMS 53617



FM 34822