



**Kennedy**

CLEANER BY DESIGN

Kennedy Hygiene Products Limited  
Brookside, Uckfield,  
East Sussex, TN22 1YA  
United Kingdom  
Telephone: +44 (0)1825 768141  
Fax: +44 (0)1825 768143  
e-mail: sales@kennedy-hygiene.com  
Website: www.kennedy-hygiene.com

## PRODUCT SPECIFICATION SHEET

### AIRPLUS

**KHP PART No: AFR AIR ELP**

### DESCRIPTION

- Air freshener designed to provide fragrance in the toilet cubicle
- Fixes to top of door using double sided adhesive pads on back of unit
- Easy load wick-based consumable that is automatically activated when the cover is closed
- Consumable lasts up to 60 days before replacement
- Self-supporting cover with secure lock which is opened using the standard product range key.

### DIMENSIONS

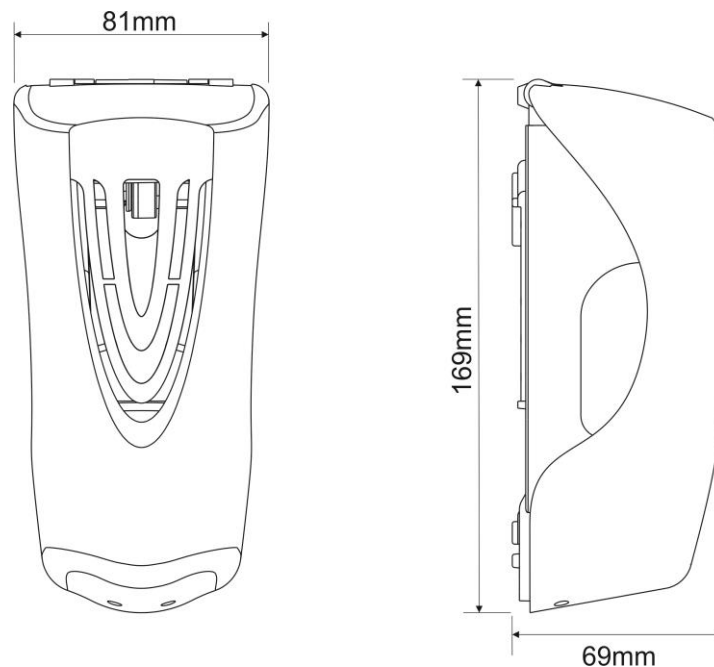

### MATERIALS

Backplate moulded in glass bead filled nylon, ABS cover and acetal mechanism.  
Dispenser can be recycled or disposed of in accordance with local regulations.

### PACKAGING

Individual Airplus dispensers are packed in a polythene bag and packed into carton holding 18.  
Individual weight: 147grams  
Carton dimensions: 34.5cm x 22.5cm x 22cm  
Total weight of carton: 3.1kg

**PSS(AFR AIR ELP) NOV 2014**



EMS 53617



FM 34822